

Question & Answer #5



People. Partnership. Performance.

P.O. Box 1837
Tacoma, WA 98401-1837
www.portoftacoma.com

PIER 4 PHASE 2 RECONFIGURATION PROJECT NO. 091251 | CONTRACT NO. 070136

1. BIDDER QUESTION

Per drawing E3.5, note 8, what is the 400a, 3p circuit breaker, type and AIC rating? This circuit breaker goes into switchboard #1 at Substation #3.

RESPONSE

The circuit breakers in Switchboard #1 are Siemens Sentron Series. The AIC rating of the breakers is 50,000 amps. The circuit breaker rating will be changed to 600A. See Addendum No. 4

2. BIDDER QUESTION

Regarding the Material Specification for “2.04 Filter Blanket” we have concerns that if this product spec is used it can be a 100% crushed rock product with up to 7% passing the #200 screen. This could pose a substantial turbidity issue. We have been a material supplier for many projects that have materials placed into the water in the greater Puget Sound region. A slight amendment to this spec would reduce this risk of a turbidity issue, an amendment that would specify that all material larger than the #4 screen be at least 90% crushed and the remaining gradation below the #4 screen be comprised of a washed sand for this application. This change will still allow the gradation to meet the WSDOT 9-03.14 (1) and still maintain the requirement of meeting the same quality or better than the rock for riprap.

RESPONSE

See Addendum No. 5

3. BIDDER QUESTION

Section 03 30 00, paragraphs 2.01.B.2 and 2.01.B.3 specify type I-II or type II cement. This specification is also referenced in the Precast Concrete (03 40 00) and Precast Pile (31 62 00) specifications. We request that the use of type III cement be allowed in precast concrete components if it satisfies the remainder of requirements in this paragraph.

RESPONSE

See Addendum #5 for revisions to Section 03 40 00 which allow Type III cement to be used with Self-Consolidating Concrete (SCC) mixes for precast deck panels and piling.

4. BIDDER QUESTION

Section 03 30 00 paragraph 2.01.B.4 specifies a maximum loss on ignition of 1% for flyash. This is extremely restrictive. We request that 1.5% loss on ignition be allowed, which is similar to WSDOT Standard Specifications for structural concrete.

RESPONSE

See Addendum #5 for revision to Section 03 33 00, paragraph 2.01.B.4 to allow loss on ignition not to exceed 1.5%.

5. BIDDER QUESTION

Section 03 30 00 paragraph 2.03.D.4 specifies a maximum slump for concrete. We request that the use of self-consolidating concrete be allowed, which would require modification of the slump requirement. Refer to the WSDOT standard specifications for recommended parameters for self-consolidating concrete.

RESPONSE

See Addendum #5 for revisions to Section 03 40 00 to allow the use of Self-Consolidating Concrete (SCC) for precast concrete deck panels and piling.

6. BIDDER QUESTION

Section 03 30 00 paragraph 3.05C1 lists defects that will require repair. This specification is also referenced in the Precast Concrete (03 40 00) and Precast Pile (31 62 00) specifications. The ¼" depth x ½" width thresholds for "defects" are quite common in precast concrete casting operation, and will not affect long-term durability. However, the chipping and patching required to repair these will be extremely expensive. For precast concrete components, we request that the defect thresholds be relaxed. A possible finish reference is WSDOT standard specifications, paragraph 6-02.3(14)B, "Class 2 Surface Finish".

RESPONSE

The defect threshold dimensions specified in Section 03 30 00, paragraph 3.05.C.1 will not be relaxed.

7. BIDDER QUESTION

Section 03 40 00 paragraph 3.01G.1 lists manufacturing tolerances for Deck Panels. We believe the (-) negative values were inadvertently omitted from the table.

RESPONSE

No, the negative values were not omitted from the manufacturing tolerances listed in Section 03 40 00, 3.01.G.1.

8. BIDDER QUESTION

Specification Section 23 09 00.01.1.02 states "Under the base bids, the controls are specified under Section 23 09 00 will be added to the project scope of work as a separate bid and pricing package." Based on this statement, control costs would be a separate line item in the bid form. Please clarify if the Port is adding a bid item for these controls or where the controls are to be priced, or is this a separate contract and not included.

RESPONSE

See Addendum No. 5

9. BIDDER QUESTION

Please take a look at the attached substitution request packet for the Pier 4 Phase 2 Marine Building job and the Fall Protection Equipment and Manufacturer specified in the details. (Attachment A)

RESPONSE

CRA Commercial Roof Anchor is an acceptable manufacturer.

10. BIDDER QUESTION

Sheet E3.3, Key Note 6 is shown between SDV23 and SDV17. Conduit schedule callouts, IE: SD62 and SL101, indicate this is between SDV17 and SDV18. Please confirm the actual vaults that conduits from key note 6, will be run to and from.

RESPONSE

See Addendum #5 for revisions to drawings E3.3, E8.4, and E8.5 regarding conduits between vaults SDV17 and SDV23.

11. BIDDER QUESTION

Attached is a Substitution Request Form and the Product Data Sheets (Attachment B).

RESPONSE

See Addendum #5 for revisions to sheets S13.1 and S41.1 to allow PZC 14 , ASTM A690, Grade 50 sheet pile to be substituted for AZ14-700, ASTM A690, Grade 50 sheet pile.

12. BIDDER QUESTION

Please see the attached substitution request concerning the manufactured storefront systems. (Attachment C)

RESPONSE

Oldcastle Building Envelope is an acceptable manufacturer.

13. BIDDER QUESTION

Reference Specification Section 00 72 00 General Conditions, Item 3 the last sentence in the paragraph states, "Mobilization and standby cost shall not be charged for equipment already present on the site." Please clarify if this applies to this scenario:

If a change order activity delays the progress of work on part or all of the project which causes this work to be stopped, will the equipment utilized in those operations be allowed to be included in a change order request at standby rates until normal work can progress? If not, how is this cost recovered?

RESPONSE

Maybe, depending on the circumstances occurring at the time. This question is too vague to provide a definitive answer. This depends on whether the equipment can be utilized elsewhere, or whether the operation can be shifted to avoid the delay. All factors will be considered at the time of the change order issuance including costs and schedule implications for other work if merited.

14. BIDDER QUESTION

Reference Specification Section 01 35 45.13. Please confirm that the Port will be identified as the "generator" in all Material Data Safety Sheets for all pre-existing hazardous material or material not brought on site by Contractor.

RESPONSE

The Port would be identified as the "generator" on waste handling manifests for pre-existing material encountered during construction. The Port will not ask the Contractor to create Safety Data Sheets for pre-existing unidentified regulated material.

15. BIDDER QUESTION

Reference Specification Section 33 10 00. If a utility owner and/or CXT Inc. causes a critical path delay notwithstanding coordination efforts by the Contractor, is the Contractor entitled to a time extension?

RESPONSE

This question is too vague to provide a definitive answer. Change orders including time extensions will be evaluated at the time of the change, site conditions at that time, work schedule etc. Refer to Article 8 of Section 00 72 00 General Conditions.

16. BIDDER QUESTION

Reference Bid Form – 00 41 00 Page 2. Bid item number 19 Pile Cutoffs (lengths greater than 10 feet). Request to change the measurement of this bid item to lineal feet. The pile cutoff length could vary dramatically and would be very difficult to capture appropriately if it was bid on a per each basis. Please confirm.

RESPONSE

The measurement for bid item 19 - Pile Cut-offs (lengths greater than 10 feet) shall remain per each.

17. BIDDER QUESTION

Are the requirements for the Washington State registered PLS land surveyor and NSPS-THSOA Certified Hydrographer noted in Section 01 71 23 – Field Engineering Part 1.04 for all surveys, including pre-post dredge surveys AND progress surveys, or just pre-post surveys?

RESPONSE

The requirements for the WA State registered PLS land surveyor and the NSPS-THSOA Certified Hydrographer noted in Section 01 71 23 - Field Engineering apply for all surveys performed for the project, including progress surveys.

18. BIDDER QUESTION

The building main structure is steel columns and beams. However, the infill between the columns on the exterior walls is wood framed, 2 x 8. All interior walls are wood framed also.

Are steel studs of the same size for the wall thickness an acceptable framing material?

RESPONSE

No, this would require the addition of continuous exterior insulation and redetailing of the project.

19. BIDDER QUESTION

Re. Specification Section 34 11 13 Track Rails – Paragraph (F) states that “prior to grouting the rails, the Engineer will perform 100% visual and ultrasonic testing of all crane rail welds by an independent testing agency ...”Paragraph (A) states “... Provide a full-time onsite Certified Welding Inspector for all welding.”Is it the Port’s intent that the Contractor provide a full-time CWI during the thermite welding of the rail splices in addition to the Engineer’s visual and UT inspection.?

RESPONSE

The requirement for the Contractor to provide a full time weld inspector will be waived. See Addendum No. 5

20. BIDDER QUESTION

The Pier 4 project was first advertised for bid on April 11th with a bid date of May 17 which allowed for a 5 week bidding period. For a job of this valued at approximately \$90 million and with the complexity this is a very tight bid period (we would typically see an 8-10 week bidding period). Our goal is to provide the Port of Tacoma with a quality bid price that does not have any scope gaps and covers the risks encountered on the project. In order to accomplish this we must have sufficient time to properly prepare the bid. With this short bid period both ourselves and our subcontractors/suppliers have difficulty chasing down and addressing the many complex details, pricing scopes, development of takeoffs, final estimate pricing and development of a pre-bid schedules. Today we have received a number of calls from our major subcontractors and suppliers that they are struggling to prepare their bids to us for this project in this short bidding window. It is requested that you please consider extending the bidding period at least 1 week to allow us sufficient time to better understand the project risk and schedule dynamics.

RESPONSE

We recognize the challenge in estimating a project of this size, unfortunately with the in-water work restrictions and the necessity to complete a portion of the pier prior to crane arrival we cannot delay initiating work. Dependent on the final question responses and/or addendum that may be forthcoming we will consider adding some time to account for any bid adjustments, but it will be very limited.

ATTACHMENTS:

ATTACHMENT A - Question No. 9 Substitution Requests

ATTACHMENT B - Question No. 11 Substitution Requests

ATTACHMENT C - Question No. 12 Substitution Requests

DIVISION 00 - PROCUREMENT AND CONTRACTING REQUIREMENTS
SECTION 00 43 25 - SUBSTITUTION REQUEST FORM - DURING BIDDING

Project Title Pier 4, Phase 2 Marine Building **Project No.** PS-12
Submitted By: Super Anchor Safety **Contract No.** _____
Prime/Sub/Supplier: Fall Protection Manufacturer **Date:** 05-05-16

Specification Title: Fall Protection **Section No.** 072270.01
Description: Additional Product Manufacturer **Paragraph:** 2.01, 2.02, 2.04
Equal to Product Specified **Page No.** 95

Proposed Substitution: CRA 12" or 18" Fall Protection Anchor & Base Plate
Trade Name: Safety **Model No.:** 1032 or 1033, 1031
Manufacturer: Super Anchor Safety
Address: 8522-216th St SE Woodinville, WA **Phone No.:** 425-488-8868

Attached data includes product description, specifications, drawings, photographs, and performance and test data adequate for evaluation of the request; applicable portions of the data are clearly identified.
Attached data also includes a description of changes to the Contract Documents that the proposed substitution will require for its proper installation.

- The Undersigned certifies:
- Proposed substitution has been fully investigated and determined to be equal or superior in all respects to specified product.
 - Same warranty will be furnished for proposed substitution as for specified product.
 - Same maintenance service and source of replacement parts, as applicable, is available.
 - Proposed substitution will have no adverse effect on other trades and will not affect or delay progress schedule.
 - Proposed substitution does not affect dimensions and functional clearances.
 - Payment will be made for changes to building design, including A/E design, detailing, and construction costs caused by the substitution.

Submitted By: Trish Garney, Super Anchor Safety
Signed By:  **Firm:** _____
Address: 8522-216th St SE, Woodinville, WA 98258
Telephone: 425-488-8868 **Email:** trish@superanchor.com

Supporting Data Attached:
 Drawings Product Data Samples Tests Reports Other _____

ENGINEER'S REVIEW AND ACTION
 Substitution approved
 Substitution approved as noted
 Substitution rejected - Use specified materials.
 Substitution Request received too late - Use specified materials.

Signed by:  **Date:** 5/9/16



SUPER ANCHOR SAFETY®

CRA Commercial Roof Anchor Instruction/Specification Manual 2016 rev.

!WARNING TO USER!
You are required to read and use the Instruction/ Specification manual supplied at the time this device was shipped. Improper use and installation can result in serious injury or death. Follow inspection requirements before each use.

CRA-12 No. 1032 / CRA-18 No. 1033
PTT and Custom Fabrication Models.
Strength Rating: 5,400lb(22.6kN)

Materials Specification:

A-36 Steel or equivalent. **Coating:** Galvanized per ASTM 123. **Riser:** 3" d. x 1/4" pipe fitted with a 5/8" d. Loop or Pass Through Top (**PTT**). **Base Plate:** 3/8" x 16" x 16".

Fastener Holes: Screws: 40- 3/8". **Bolts:** 8-9/16". 3/8" drain holes in riser and base.

Serial No.: Stamped or riveted tag. **Flashings:** Optional ABS Storm Cap and Flashing Base.

See **Figs. 8-9**. Includes fastener pack **No. 2022**: 40 ea. No. 14x2.5" hex head screws for wood or metal.

Use only **SAS** factory supplied fasteners.

Custom Fabrication/Engineering/Field Welding models are available upon request.

Specification of Use:

Fall Arrest: 1 person. **Work Positioning:** 4 persons. Maximum body wt. each person of 310lb(140kg).

PPE Energy absorbers required for each worker. **Horizontal Line:** See **PTT** section page 2.

Non-specified use: Do Not Use for scaffolding tie off or hoisting equipment.

PPE Compatibility: Recommend to use **SAS** safety equipment for "Ensured" compatibility.

Window Washing Anchor:

Compliance: IWCA I-14.1-2001: Support 5,000lb(22.5kN) in any direction

a load is applied. **OSHA 1910.66 App.C** Non-Mandatory Guidelines Section II Article (2)

Requires bolt attachment as shown at **Fig. 7**, or engineering by a qualified person.

Structural Engineering:

CRA attachment point must be capable of supporting 5,000lb(22kN) or 2 times the intended fall protection load when industrial safety standards permit. All substrates and metal decks must be attached to supporting structure per current building code requirements.

Attachments not specified in this manual: Contact **SAS** for custom or engineered solutions.

Plywood/OSB Sheathing Installation:

Install anchors onto 3/4" plywood with fastener pack **No. 2022**, (40 screws). For plywood less than 3/4" or **OSB**, a 3/4" backer is required as shown at **Fig. 2** or **2-B**. Visually inspect fastener penetration is a minimum of 3/4". Do not install onto plywood that has water damage, cracks, cuts, or delamination.

Metal Decking 20 Gauge Minimum:

Use 36 screws from fastener pack **No. 2022** to penetrate the raised channel section as shown at **Figs. 3,4**

18 gauge or less: Install metal backer panel shown at **Fig. 5** using same width and 36" length. Or

1/2" x 48" x 48" plywood base over the metal decking. **Insulation Board:** Screw fasteners must not exceed 6" in length. For thicknesses greater than 6", bolts are required or an engineered fastener system.

Steel /Wood Beams/Insulation Board / Bolt Attached:

Minimum of 4 each grade 5 x 1/2" d. "All Thread" or grade 8 bolts/ nuts as shown at **Fig. 7**. Bolts must extend aprx. 1/2" through the nut on the underside. **SAS** factory supplied backer plates and bolts are required for steel/wood beams.

Concrete Minimum Strength 2,000 p.s.i. x 4" thickness:

8 ea. 1/2" x 6,000lb(27kN) tensile strength bolts engineered for concrete embedment and installed per bolt mfg. specifications. See **Fig. 6**. For concrete less than 4" thick, use a 16x16x3/8" steel backer plate supplied by **SAS** or an engineered specification.

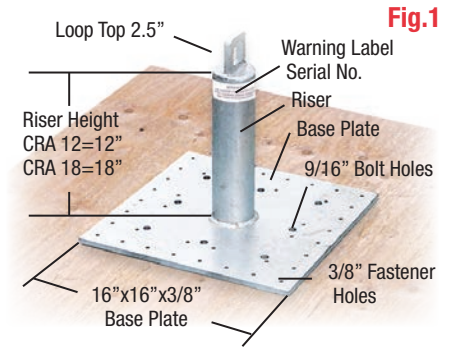

Fig. 1

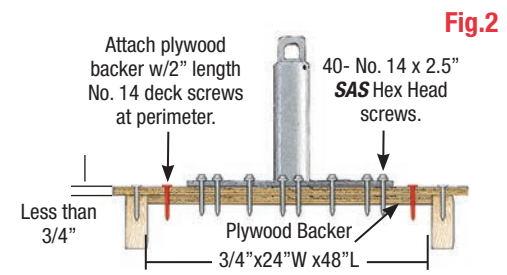

Fig. 2

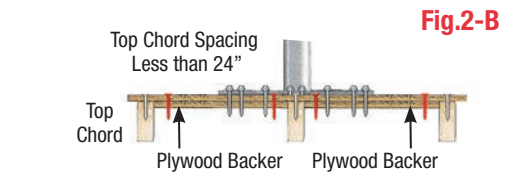

Fig. 2-B

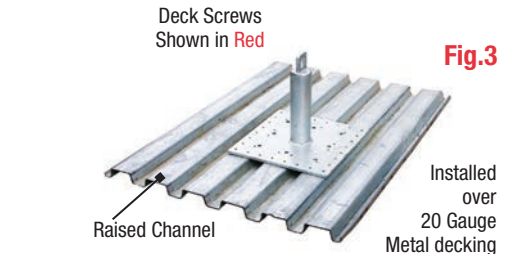

Fig. 3

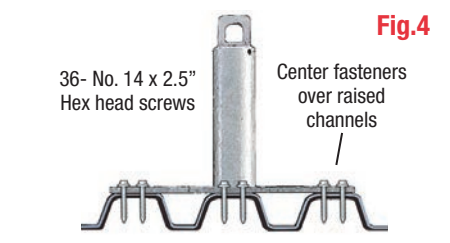

Fig. 4

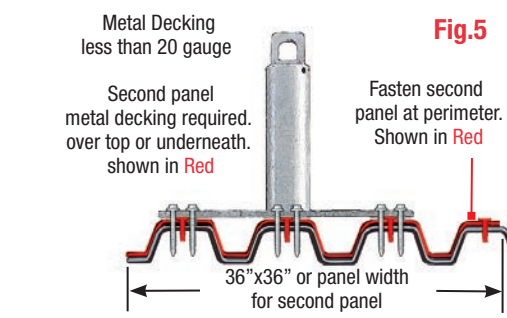

Fig. 5

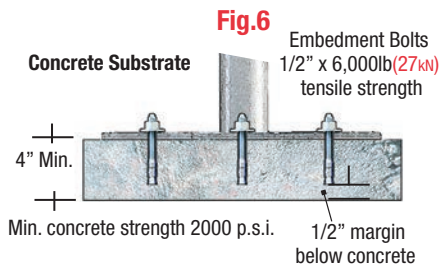

Fig. 6

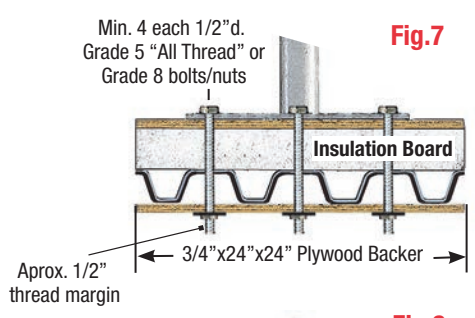

Fig. 7

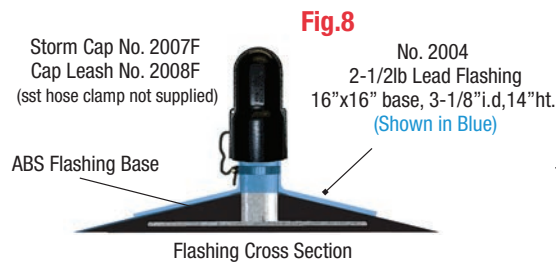

Fig. 8

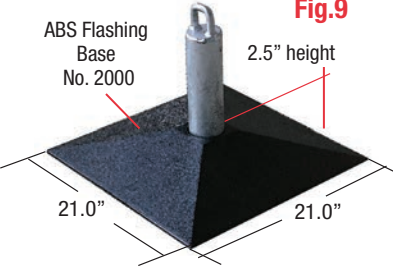

Fig. 9

Anchor Spacing:

Recommended spacing between anchors is $20\pi(6m)$ as shown at Figs.16,17,18. Maximum horizontal line length is $120\pi(36m)$. Set anchors 6- $10\pi(2-3m)$ from leading edges. Consult SAS plan service for anchor locations.

PTT Anchors / Horizontal Line System (HLS):

The Pass Through Top (PTT) is designed for a Horizontal Line System (HLS). Shown at Fig.10, O-Ring No. 5010, is installed onto a 3/8" d. steel cable No. 1055. PPE is connected to the O-Ring and passes through the PTT by rotating the ring. HLS components have a minimum breaking strength of 5,000lb(22.6kN.)

HLS Factory Engineered System: Fall Arrest = 1 person. Work Positioning 4 persons. Additional workers may be added when specified by an engineer or qualified person in a written plan.

Specification for Factory Engineered System:

Warning: Only SAS supplied HLS components qualify as a "Factory Engineered System". Components supplied by others require engineering by a qualified or competent person.

Corners/Ends: Use only loop top models No. 1032-1033 shown at Figs.16,18.

Intermediate Anchors: No. 1032-P/1033-P shown at Figs.10,17.

Cable: No. 1055 galvanized 3/8" - 7x19 steel cable.

End Loops: Use 3 SAS No. 1056 Crosby clamps or equal for each end loop as shown at Fig.12.

Turnbuckles: No. 1058-3/4" galvanized Jaw-Jaw type. Lengths over 60ft.(18m) use turnbuckles on both ends.

Metal Energy Absorber: No. 1059 is equipped with Tension and Force indicators.

Absorber Coupler No. 1053, Fig.11-B, is required to link a turnbuckle to a Metal Energy Absorber.

PTT/PPE Adaptor No. 1054 shown at Fig.19, converts a PTT top fixture into a loop top for attachment of fall protection equipment.

O-Ring No. 5010 Require one per worker. Insert onto cable before forming end loops.

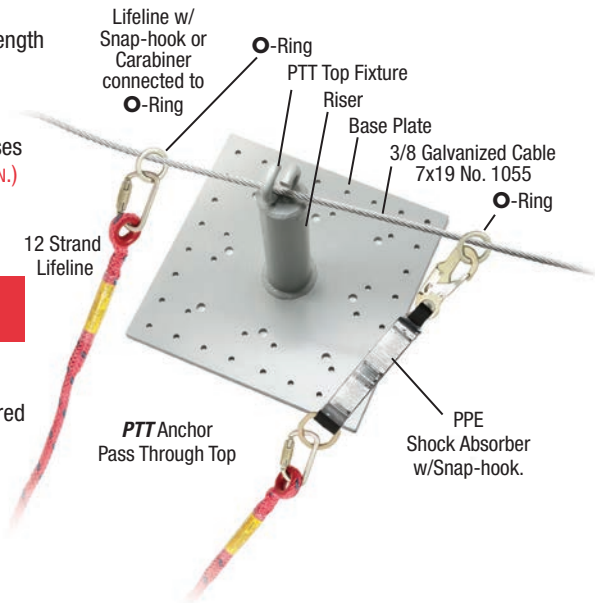

Cable Attachment / Cable Length Calculation:

Cable length is the distance between two ends or corners plus 18" for each loop as shown at Figs.12&16. Do not add 18" when turnbuckles or energy absorbers are used. See Figs.18,11-A. Connect Turnbuckles to anchors or loop ends with factory supplied shackle and cotter pin. Some Turnbuckles have a lock nut. Cotter pins are required to prevent accidental disengagement. An equal size grade 8 bolt and lock nut may be substituted. **Cable end loops:** are required to be formed as shown at Fig.12 for all terminations or connections to turnbuckles and energy absorbers. Use a torque wrench to evenly tighten all clamp nuts to 45lb. **Cable Tension:** Tighten turnbuckles leaving a minimum of 2" of slack in the line. **WARNING! DO NOT** over tighten cable to prevent damage to the anchor fasteners and supporting structure. **Non-Specified Use:** Do not use PTT anchors for corners or ends. **WARNING! DO NOT** attach fall protection equipment to a PTT anchor top, cable loop end, turnbuckle or around the riser as it may result in unintentional disengagement when subjected to a static load or in service loading (free fall) .

Inspection / Maintenance:

Inspect all components of the HLS prior to each use. Do not use if any of the following conditions are present:

- **Cable:** Broken, cut, frayed, or creased strands.
- **Clamps:** Loose or Missing clamps/ nuts.
- **Turnbuckles:** Loose, missing cotter pins, Broken or bent.
- **O-Ring:** Missing, bent, out of round. Replace.
- **Energy Absorber:** Attachment bolt/nut missing, or loose. Tension indicator visible. Cable is too tight. Loosen turnbuckle. Fall Indicator visible: Do Not Use if HLS has been subjected to a force load or used by wire walkers.
- **CRA/PTT:** Loop/PTT top or riser is bent. Anchor is loose.

Free Fall / In Service Loading:

HLS components subjected to a free fall or other force must be removed and replaced before further use.

Anchors: Are not required to be replaced provided they have been inspected by a "qualified person" or engineer and there is no evidence of damage to the anchor, the fasteners or the supporting structure.

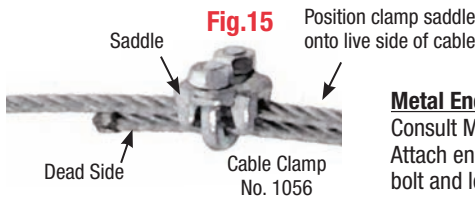
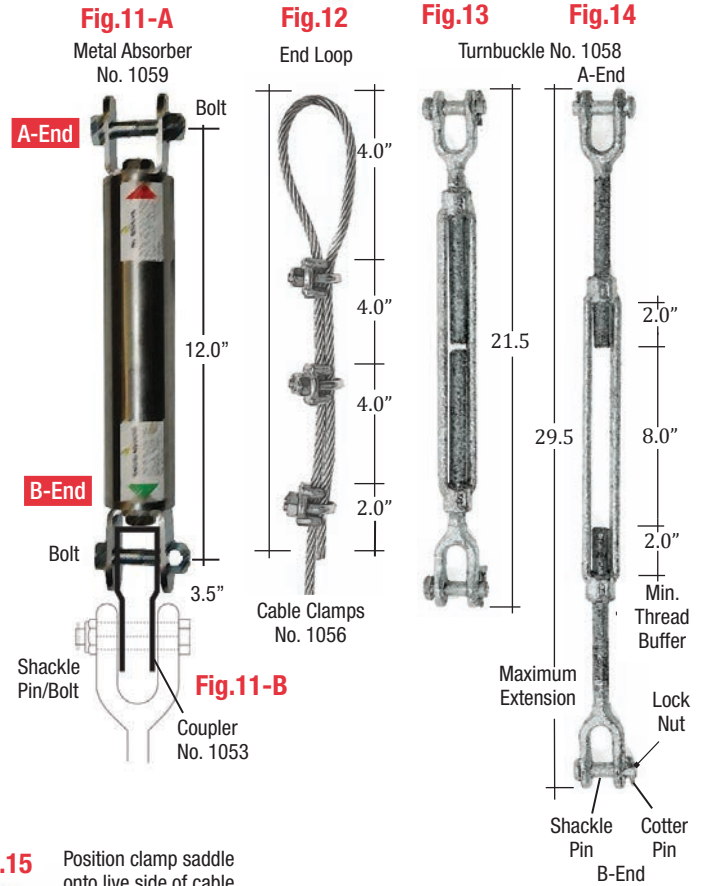

Metal Energy Absorber:

Consult Metal Energy absorber instructions before use. Attach end "A" to CRA Loop top with SAS M12x60mm sst. bolt and lock nut, and B-end of absorber to cable loop end, Fig.12. **With Turnbuckle:** Attach Turnbuckle A-end to CRA Loop top. Use Absorber Coupler No. 1053, Fig.11-B, to attach B-end of absorber to turnbuckle B-end and A-end to a cable loop. **Tension Indicator:** Absorber B-end green arrow indicates the correct amount of tension when the interior indicator is NOT visible. **Force Indicator:** A-end red arrow interior indicator will be visible when the HLS has been subjected to a force load. If deployed DO NOT USE HLS and determine cause.

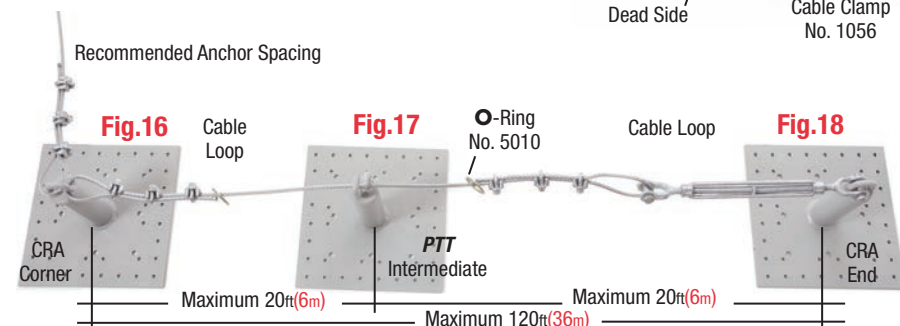

8522-216th St SE ♦ Woodinville, WA 98072
Phone: (425) 488-8868 ♦ Fax: (360) 668-1717



“The Best in Fall Arrest”

SUPER ANCHOR SAFETY

Warranty & Statement of Compliance

Warranty:

Super Anchor Safety warrants to the purchaser that all products are free from defect in material and workmanship at the time of shipment. This warranty is limited to product replacement for a period of one (1) year from the date of installation or use by the owner, provided that this period shall not exceed two (2) years from the date of shipment. This warranty only covers defects in material and workmanship. It does not cover conditions resulting from normal wear, neglect, abuse, or accident. This warranty is non transferable. Any unused defective product will be replaced at no charge by returning it to Super Anchor Safety or the Distributor that it was purchased from.

Statement of Compliance:

Super Anchor Safety products comply with industrial safety standards as specified on the label at time of shipment. Instruction/Specification Manuals and Product label copies are available at www.superanchor.com or by calling 425-488-8868.

Project Name	Project Address	Product Type	Architect	Architect Phone
Edmonds Woodway School	Edmonds, WA	CRA System	Rolluna Architects	206-624-4222
Mountlake Terrace School	Mountlake Terrace, WA	CRA System	Rolluna Architects	206-624-4222
Shahalla Middle School	Vancouver, WA	CRA System	LSW Architects	360-694-8571
University of Nebraska	Lincoln, NE	CRA System	Mackey Mitchel Architects	314-694-8571
Fire Station #6 - Seattle	Seattle, WA	CRA System	Weinstein Architects AU	206-443-8606
Fire Station #5 - Seattle	Seattle, WA	CRA System	Seattle Structural	206-343-3000
Hollywood Loft Apartments	Seattle, WA	CRA System	Hewitt	206-624-0541
Woodward Middle School	Bainbridge Island, WA	CRA System	Coates Design Architects	206-780-0876
Bellevue Way & Main	Bellevue, WA	CRA System	Baylis Architects	425-454-0566
Hirabayashi Apartments	Seattle, WA	CRA System	Mithun Architects	206-623-3344
The Astro	Seattle, WA	CRA 18"	Runberg Architects	206-956-1970
Aero Apartments	Everett, WA	CRA 18"		
Legacy Town Square	Redmond, WA	CRA System	Tiscareno Associates	206-325-3356
2051 East Madison	Seattle, WA	CRA System	Mithun Architects	206-623-3344
Platinum Triangle Apartments	Anaheim, CA	CRA Window	JPI/TDI Sr. Design	619-888-9968
Plaza Roberto	Seattle, WA	CRA Window	SMR Architects	206-623-1104
Bel-Red Apartments	Bellevue, WA	CRA Window	Group Architects	206-635-1230
Modera Capitol Hill	Seattle, WA	CRA Window	Studio Meng Strazzara	206-587-3797
Trident Submarine Base	Bangor Naval Shipyard	CRA System	Classified	
Naval Undersea Warfare Center	Naval Base - Kitsap, WA	CRA System	Classified	
Puget Sound Naval Shipyard	Naval Base - Kitsap, WA	CRA System	Classified	



SUPER ANCHOR SAFETY

CRA-Anchor Specifications Engineers Report:

Model Specification:

CRA-12 / CRA-18

Loop or PTT Top Fixture:

Loop Top: Rated for PPE connector attachments.

PTT Top: Rated for wire cable horizontal line use.

Materials Specification:

Riser: A-36 steel pipe 1/4" wall thickness x 3.0" o.d. diameter or equivalent.

Base Plate: A-36 steel x 3/8".

Top Fixtures: 5/8" A-36 steel rod.

Coating: Hot dip galvanized per ASTM -A123 or ASTM -A153 or architect specified.

Installation Specifications:

Mechanical Fastening:

See CRA Instruction/Specification

Manual: Required minimum: 36 ea.

#14 hex head screws of sufficient length to penetrate the substrate by at least 1.0" and rated for the substrate material type.

Concrete Slab 2,500 psi min.

4" thickness: Use 9/16" holes shown in red: Required 8 ea. 1/2" d. 6,000lb tensile strength bolts rated for concrete embedment

Bolt Attach:

Use 9/16" holes shown in red:

See Bolt Attachment Specifications:

A minimum of 4 each, 1/2" d. grade 8, Stainless Steel, or grade 5 all thread and lock nuts.

Structural Engineering:

Steel plate, I beam, structural member capable of supporting 5,000lb(22kN) or two times the intended fall protection load.

Engineering Stamp:

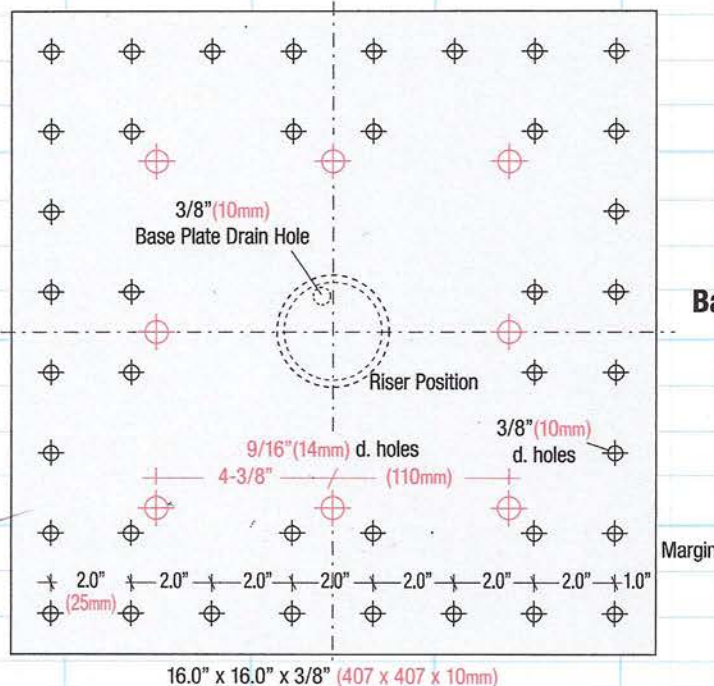
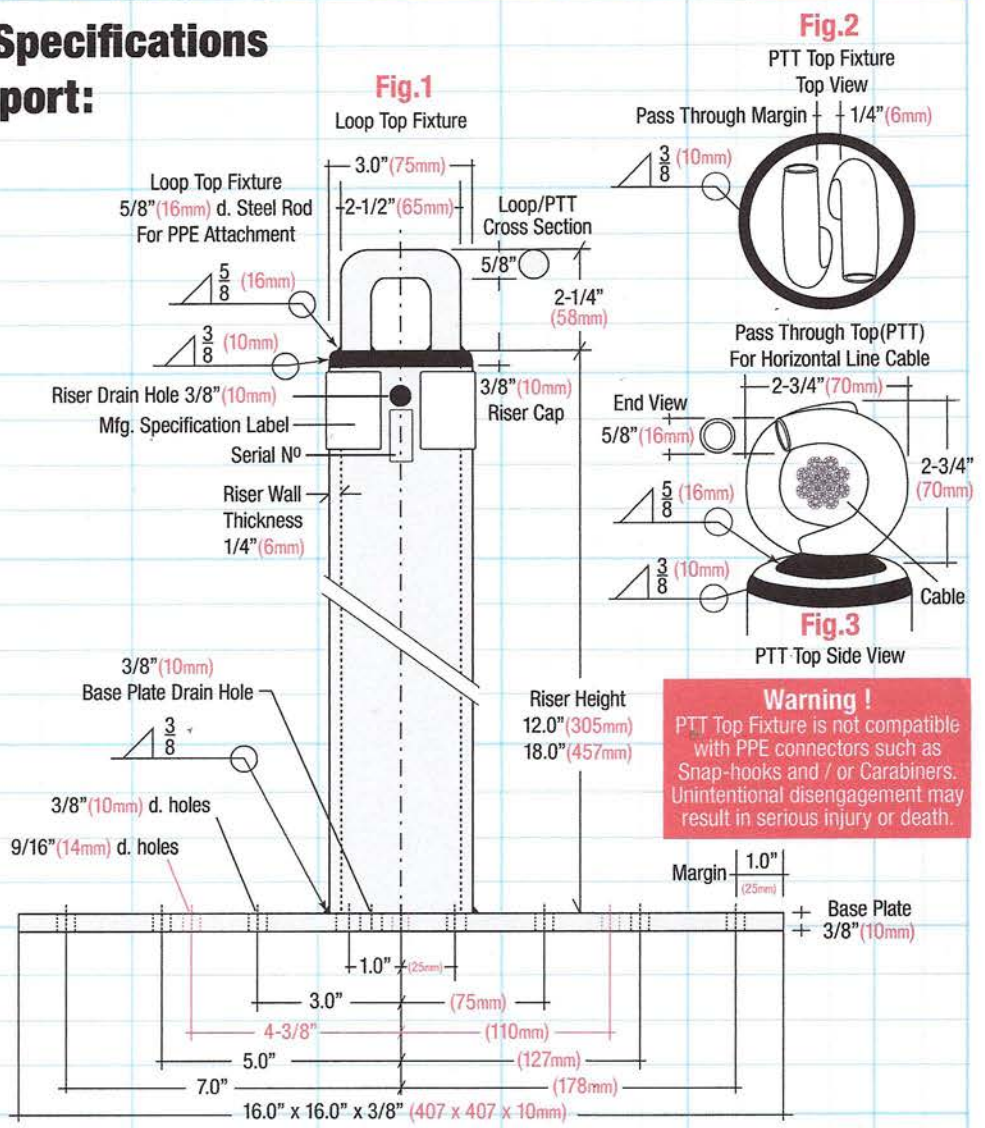
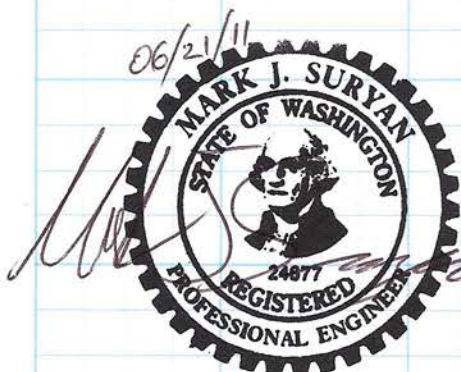



SUPER ANCHOR SAFETY

SAS-CRA Load Test Report # 0802-1005c March 17, 2008

CRA Anchor installed over 3/4" plywood with 3/4" plywood backer.

- Anchor attachment to primary substrate:
40 each 2-1/2" x 14 gauge hex head screws.
- Backer Board:
24" x 4 8" 3/4" plywood attached to primary substrate with 21 each 2" x 14 gauge deck screws 8" on center.

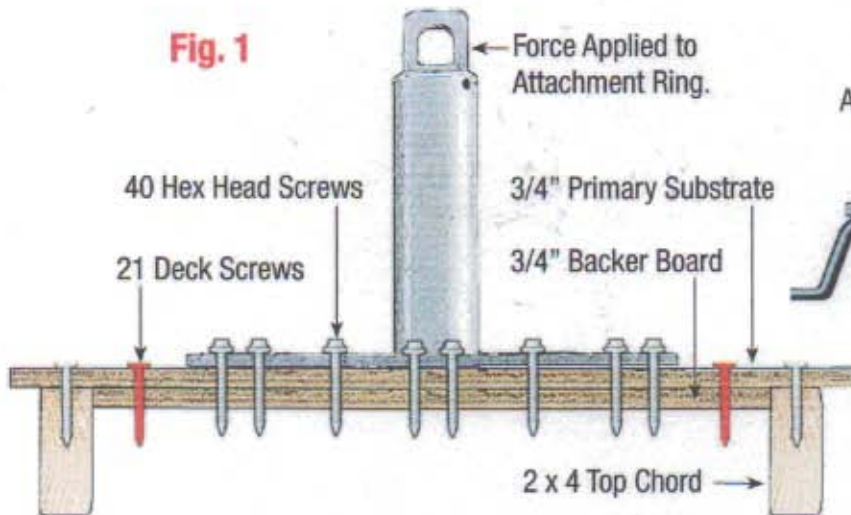

CRA Anchor installed over 20 gauge steel decking.

- Anchor attachment to steel decking:
36 each 2" #14 gauge hex head screws.

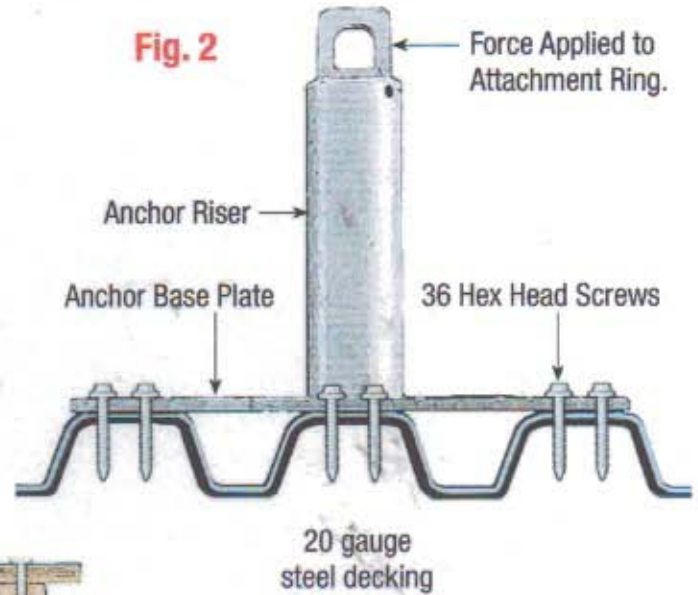

Fig. 1

Bare plywood with 3/4" backing plate added	5,292lb (2,400kg)	Roof system failure
Bare plywood with 3/4" backing plate added	5,279lb (2,394kg)	Roof system failure
Bare plywood with 3/4" backing plate added	5,607lb (2,543kg)	Roof system failure

Average 5,392lb (2,445kg)

Fig. 2

Corrugated metal roofing panel on plywood with 1/4" x 2" tag screws	6,829lb (3,097kg)	Screw pulled from corrugated metal
---	-------------------	------------------------------------

This report has been prepared for the exclusive use of Super Anchor Safety. Any reproduction or transmittal of this document must be done so in its entirety and with written permission from Super Anchor Safety.

Thank you for using Dynamark Engineering, Inc. Please give me a call 425-483-4447 or e-mail mark@dynamark-engineering.com, if you have any questions regarding this information, or when we can be of further assistance.

Reviewed by: Leesa J

Sincerely,

Mark J. Surhan



EXPRES 03/11/10



Certificate No. 0802-1005b

March 5, 2008

Mr. Chris Lagerstedt
Super Anchor Safety
8522 216th St SE
Woodinville, WA 98072-8009

Subject: Load testing: Anchor post sample

Dear Mr. Lagerstedt:

Per your request, we performed load testing on a sample anchor post provided by Super Anchor. The testing was performed using our Satec-Baldwin Model 120,000 BTE Universal Testing Machine, DEI 100, which is in current calibration and traceable to (NIST). The results of the load tests are summarized in Table 1. Figures 1-3, attached, show the test setup and the failure modes of the sample.

Table 1. Load Test Results for Anchor Post

Test Mode	Lateral Load [lb]	Failure Mode
Proof	5,000	no failure
Ultimate Strength of Loop	7,270	weld fracture
Ultimate Strength of Base	12,620	weld fracture & large deflection

This report has been prepared for the exclusive use of Super Anchor Safety. Any reproduction or transmittal of this document must be done so in its entirety and with written permission from Super Anchor Safety.

Thank you for using Dynamark Engineering, Inc. Please give me a call at 425.483.4447, or email mark@dynamark-engineering.com, if you have any questions regarding this information, or when we can be of further assistance.

Reviewed by: Leesa Johansen 

Sincerely,

Mark J. Suryan, PE

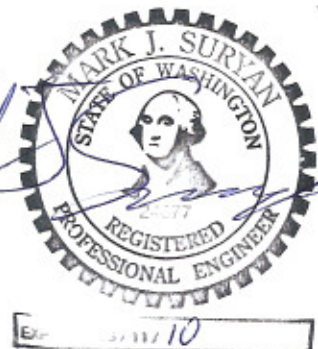

Photos attached (3)

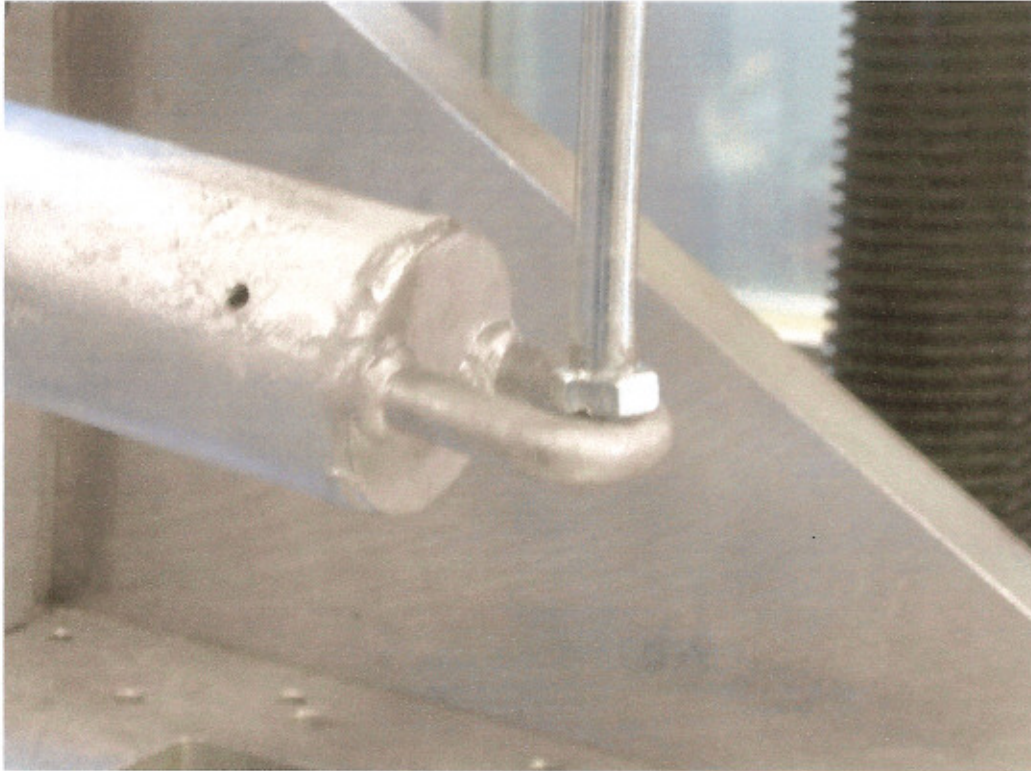

Figure 1. Sample during 5,000 lb proof load on end of welded loop.

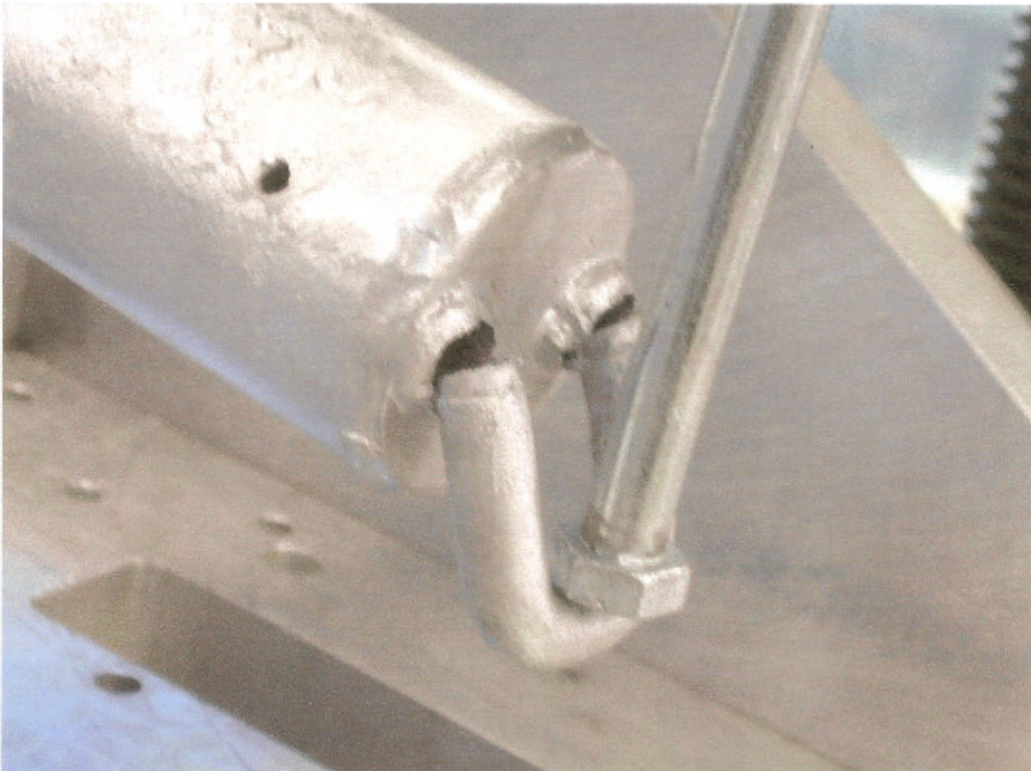

Figure 2. Sample after ultimate strength test on end of loop.

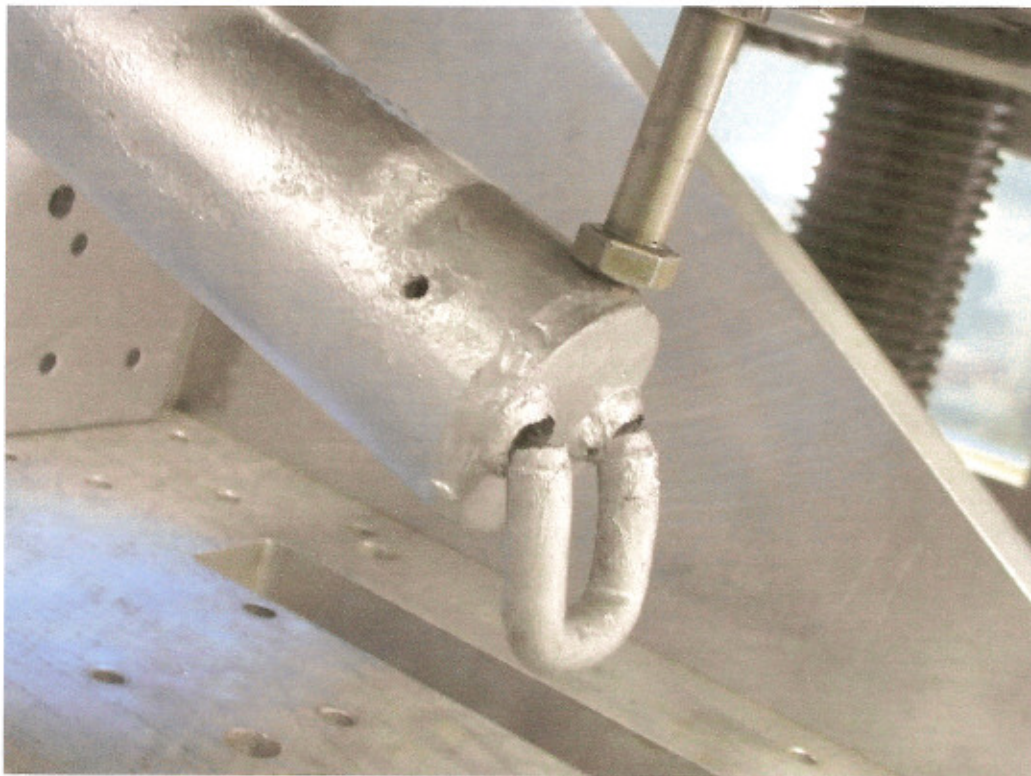

Figure 3. Sample after ultimate strength test on end of loop.

DIVISION 00 - PROCUREMENT AND CONTRACTING REQUIREMENTS
SECTION 00 43 25 - SUBSTITUTION REQUEST FORM - DURING BIDDING

Project Title PIER 4 PHASE 2 RECONFIRGUATION (091251)

Project No. _____

Submitted By: Marla Wallace

Contract No. 070136

Prime/Sub/Supplier: Supplier

Date: 5/5/16

Specification Title: Drawing S41.1 Steel Sheet Pile Details

Section No. A

Description: AZ14-700 Sheet Pile (ASTM A690, Grade 50)

Paragraph: Top Left Diagram

Page No. 379 of 499

Proposed Substitution: PZC 18, PZC 13 or PZC 14 Sheet Pile (ASTM A690, Grade 50)

Trade Name: Z Sheet Pile

Model No.: PZC 18, PZC 13, PZC 14

Manufacturer: Gerdau

Address: 25801 Hofheimer Way, Petersburg, VA.

Phone No.: 804-520-0286

Attached data includes product description, specifications, drawings, photographs, and performance and test data adequate for evaluation of the request; applicable portions of the data are clearly identified.

Attached data also includes a description of changes to the Contract Documents that the proposed substitution will require for its proper installation.

The Undersigned certifies:

- Proposed substitution has been fully investigated and determined to be equal or superior in all respects to specified product.
- Same warranty will be furnished for proposed substitution as for specified product.
- Same maintenance service and source of replacement parts, as applicable, is available.
- Proposed substitution will have no adverse effect on other trades and will not affect or delay progress schedule.
- Proposed substitution does not affect dimensions and functional clearances.
- Payment will be made for changes to building design, including A/E design, detailing, and construction costs caused by the substitution.

Submitted By: Marla Wallace

Signed By: 

Firm: LB Foster Company

Address: 32970 Alvarado Niles Road Suite# 736

Telephone: 510-240-4401

Email: mwallace@lbfooster.com

Supporting Data Attached:

Drawings Product Data Samples Tests Reports Other _____

ENGINEER'S REVIEW AND ACTION

Substitution approved

Substitution approved as noted

Substitution rejected - Use specified materials.

PZC 14 , ASTM A690, Grade 50 sheet pile may be substituted for AZ14-700, ASTM A690, Grade 50 sheet pile.

DIVISION 00 - PROCUREMENT AND CONTRACTING REQUIREMENTS
SECTION 00 43 25 - SUBSTITUTION REQUEST FORM - DURING BIDDING

Substitution Request received too late - Use specified materials.

Signed by: _____

Date: 5/6/16

Hot Rolled
Domestically Produced
Ball & Socket Sheet Pile

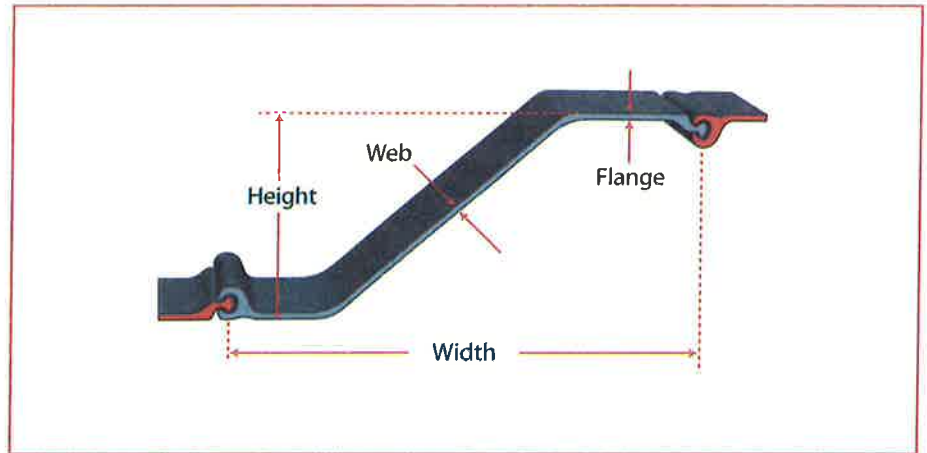

Available Grades: ASTM A572 Gr. 50 and 60, A588 and A690

The innovative PZC series of steel sheet piling is manufactured to be wider, lighter, and stronger than the traditional PZ piling.

PZC sheet piling is made wider than PZ sections to maximize jobsite production in setting and driving. They are lighter than PZ piling to minimize the required amount of steel needed for project installation. And PZC sections are stronger per pound than PZ sections in both section modulus and moment of inertia.

- PZC 13 compared to the currently produced PZ 22:
- 27 % wider laying dimension
 - 36 % stronger per pound

Dimensions and Properties

Section	Width	Height	Web Thickness	Flange Thickness	Weight		Moment of Inertia		Section Modulus		Nominal Coating Area
	in.	in.	in.	in.	lb / lft	lb / ft ²	in ⁴	in ⁴ / wft	in ³	in ³ / wft	ft ² / lft
	mm	mm	mm	mm	kg / lm	kg / m ²	cm ⁴	cm ⁴ / wm	cm ³	cm ³ / wm	m ² / lm
PZC 12	27.88	12.52	0.335	0.335	46.4	20.0	326.6	140.6	52.0	22.4	5.60
	708	318	8.5	8.5	69.1	97.6	13,595	19,202	851	1,202	1.71
PZC 13	27.88	12.56	0.375	0.375	50.4	21.7	353.0	152.0	56.2	24.2	5.60
	708	319	9.5	9.5	75.1	106.0	14,694	20,753	920	1,300	1.71
PZC 14	27.88	12.60	0.420	0.420	55.0	23.7	382.7	164.8	60.5	26.0	5.60
	708	320	10.7	10.7	81.8	115.5	15,930	22,499	991	1,400	1.71

PZC 14

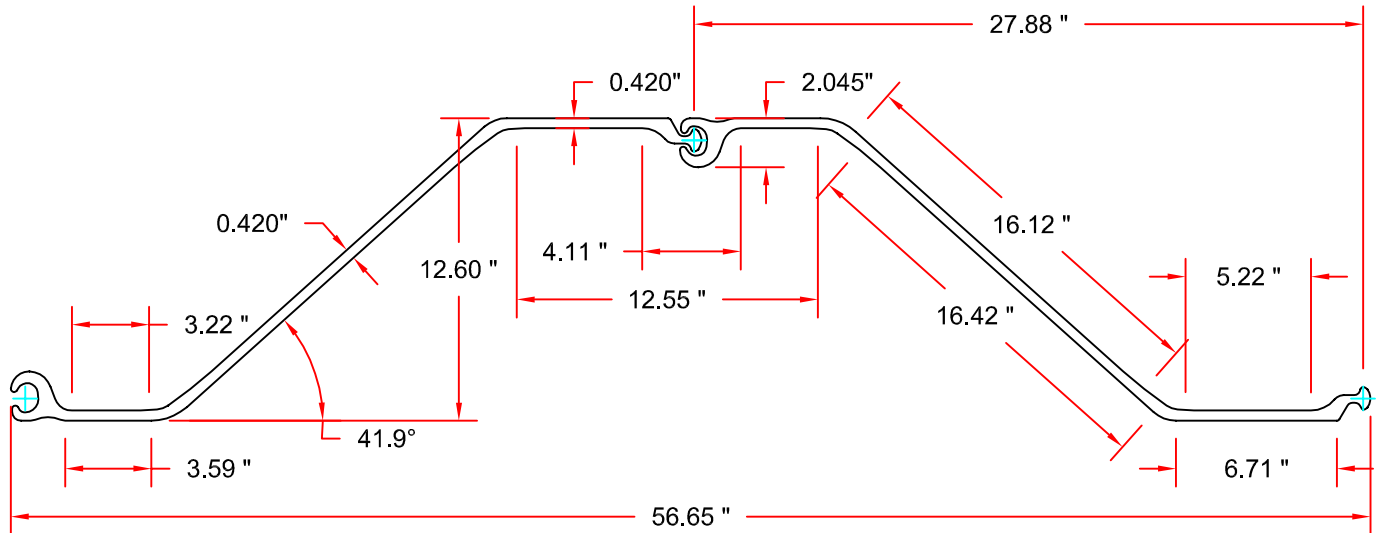
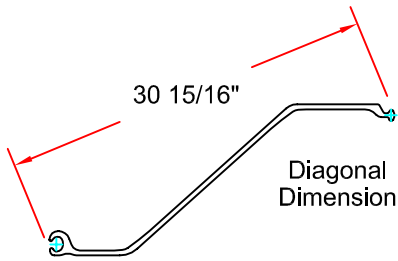

Sheet Pile Section Properties										
Nominal Width (in)	Area (in ²)		Weight (lbs)		Moment of Inertia (in ⁴)		Section Modulus (in ³)		Surface Area (ft ² / ft)	
	Single Section	Per Linear Foot of Wall	Per Foot of Sheet	Per Square Foot	Single Section	Per Linear Foot of Wall	Single Section	Per Linear Foot of Wall	Total Area	Nominal Coating Area *
27.88	16.15	6.95	55.0	23.7	382.7	164.8	60.5	26.0	6.10	5.60

* Excludes socket interior & ball of interlock.

Available Material Grades: ASTM A572 Grade 50 and 60, Also A588 and A690.

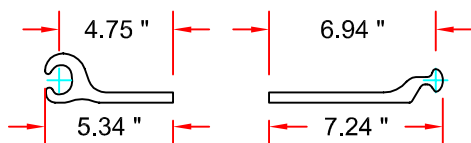

Flange Dimensions

LB Foster

PILING DIVISION
L.B. FOSTER COMPANY
SUWANEE, GA 30024

TITLE				SHEET PILING DIMENSIONS & PROPERTIES				
PROJECT				PZC14 STEEL SHEET PILE				
CUSTOMER	N/A			FILE	X:\PL\Eng\Design Manual\Sheet Pile\J			
PROJ #	11-052	SO#	N/A	SP-DC14				0
DRAWN	TWT	DATE	07/29/11					
CHK'D		SCALE	1-1/2"=1'0"	DWG #	SHT 1 of 1		REVISION	

RO	08/01/11	Issued for Review and Comment.
REV.	DATE	DESCRIPTION

PZC 18

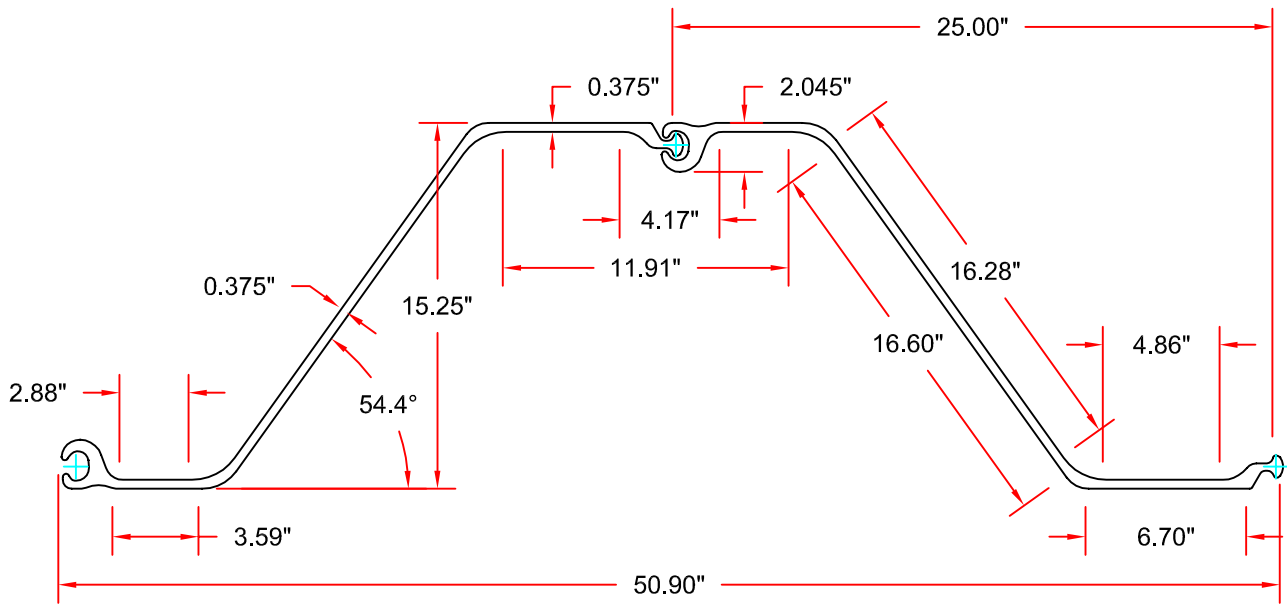
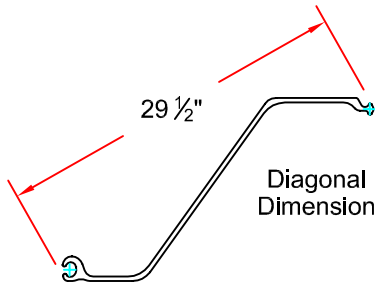

Sheet Pile Section Properties										
Nominal Width (in)	Area (in ²)		Weight (lbs)		Moment of Inertia (in ⁴)		Section Modulus (in ³)		Surface Area (ft ² / ft)	
	Single Section	Per Linear Foot of Wall	Per Foot of Sheet	Per Square Foot	Single Section	Per Linear Foot of Wall	Single Section	Per Linear Foot of Wall	Total Area	Nominal Coating Area *
25.00	14.82	7.12	50.4	24.2	532.2	255.5	69.8	33.5	6.10	5.60

* Excludes socket interior & ball of interlock.

Available Material Grades: ASTM A572 Grade 50 and 60, Also A588 and A690.

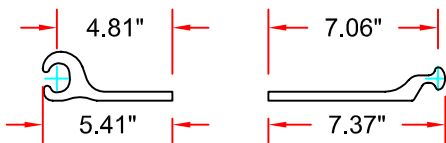

Flange Dimensions

LB Foster

PILING DIVISION
L.B. FOSTER COMPANY
SUWANEE, GA 30024

TITLE				SHEET PILING DIMENSIONS & PROPERTIES			
PROJECT				PZC18 STEEL SHEET PILE			
CUSTOMER		N/A		FILE		X:\PL\Eng\Design Manual\Sheet Pile\J	
PROJ #	11-052	SO#	N/A	SP-DC18		0	
DRAWN	TWT	DATE	07/29/11				
CHK'D		SCALE	1-1/2"=1'0"	DWG #		SHT 1 of 1	REVISION

RO	08/01/11	Issued for Review and Comment.
REV.	DATE	DESCRIPTION

Z Pile Profile

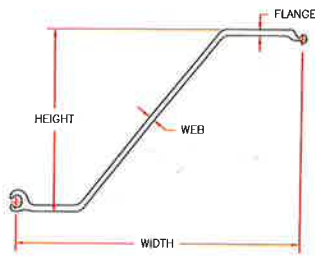

Cover Plated Z Profiles

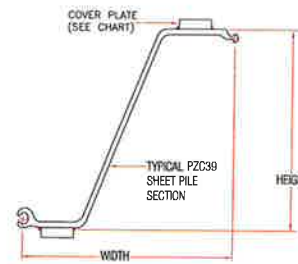

Section	Width+		Height+		Web Thick-ness+		Flange Thick-ness+		Weight		Moment of Inertia		Section Modulus		Nominal Coating Area*
	in.	in.	in.	in.	in.	in.	lb / lft	lb / ft ²	in ⁴	in ⁴ / wft	in ³	in ³ / wft			
	mm	mm	mm	mm	mm	mm	kg / lm	kg / m ²	cm ⁴	cm ⁴ / wm	cm ³	cm ³ / wm	m ² / lft		
PZC 13	27.88	12.56	0.375	0.375	50.4	21.7	353.0	152.0	56.2	24.2	5.60				
	708	319	9.5	9.5	75.1	106.0	14,690	20,760	920	1,300	1.71				
PZC 14	27.88	12.60	0.420	0.420	55.0	23.7	381.6	164.3	60.5	26.0	5.60				
	708	320	10.7	10.7	81.8	115.5	15,890	22,440	990	1,400	1.71				
PZC 18	25.00	15.25	0.375	0.375	50.4	24.2	532.2	255.5	69.8	33.5	5.60				
	635	387	9.5	9.5	75.1	118.2	22,150	34,890	1,145	1,800	1.71				
PZC 19	25.00	15.30	0.420	0.420	55.0	26.4	576.3	276.6	75.3	36.1	5.60				
	635	388	10.7	10.7	81.8	128.8	23,990	37,780	1,235	1,945	1.71				
PZC 25	27.88	17.66	0.485	0.560	69.4	29.9	938.7	404.1	106.3	45.7	6.15				
	708	449	12.3	14.2	103.3	145.9	39,070	55,190	1,740	2,455	1.87				
PZC 26	27.88	17.70	0.525	0.600	73.9	31.8	994.3	428.1	112.4	48.4	6.15				
	708	450	13.3	15.2	110.0	155.4	41,390	58,460	1,840	2,600	1.87				
PZC 28	27.88	17.75	0.570	0.645	79.0	34.0	1,057	455.1	119.1	51.3	6.15				
	708	451	14.5	16.4	117.6	166.1	44,000	62,150	1,950	2,755	1.87				
PZC 37	22.50	21.02	0.488	0.563	69.6	37.1	1,349	719.6	128.4	68.5	6.15				
	572	534	12.4	14.3	103.6	181.2	56,160	98,270	2,100	3,680	1.87				
PZC 39	22.50	21.05	0.525	0.600	74.0	39.5	1,429	762.1	135.6	72.3	6.15				
	572	535	13.3	15.2	110.2	192.8	59,480	104,100	2,220	3,890	1.87				
PZC 41	22.50	21.09	0.561	0.636	78.4	41.8	1,507	803.6	142.7	76.1	6.15				
	572	536	14.2	16.2	116.6	204.1	62,720	109,700	2,340	4,090	1.87				

Available Grades: ASTM A572 Gr. 50 and 60, A588 and A690

+Values stated are nominal

*Both sides of sheet: excludes socket interior and ball interlock

PZC™ is a trademark of Gerdau

Section	Normal Width	Plate Size	Per Single Section				Per Unit of Wall				
			Area	Weight	Total Surface Area	Nominal Coating Area*	Weight		Moment of Inertia	Section Modulus	
							Full Length Plates	Half Length Plates			
in.	in.	in ²	lb / ft	ft ² / lin ft	ft ² / lin ft	lb / ft ²	lb / ft ²	in ⁴ / ft	in ³ / ft		
mm	mm	mm ²	kg / m	m ² / m	m ² / m	kg / m ²	kg / m ²	cm ⁴ / m	cm ³ / m		
PZC 46-CP (PZC39)	22.5	3 x 0.500	24.76	84.2	6.82	6.32	44.9	42.1	947.8	86.0	
	572	76 x 13	159.8	125.2	2.08	1.93	219.3	205.6	129,400	4,630	
PZC 48-CP (PZC39)	22.5	3 x 0.625	25.51	86.7	6.86	6.36	46.3	42.9	997.0	89.4	
	572	76 x 16	164.6	129	2.09	1.94	226.1	209.5	136,100	4,810	
PZC 50-CP (PZC39)	22.5	3 x 0.8125	26.64	90.6	6.92	6.42	48.3	43.9	1,073.0	94.6	
	572	76 x 21	171.9	134.8	2.11	1.96	235.9	214.4	146,400	5,090	

Available Grades: ASTM A572 Gr. 50

*Excludes socket interior and ball interlock

• Fillet weld should be sized to adequately resist design loads and should be continuous and all around.

• Cover plate length depends upon moment curve. Best economy is obtained when plate length is limited to area of high moment.

Project Title: PIER 4 MARINE BLOC Project No.: 091251
Submitted By: CHRIS MUIR Contract No.: 070136
Prime/Sub/Supplier: REGIONAL GLASS Date: 05/05/2016

Specification Title: ALUMINUM FRAMED STOREFRONTS Section No.: 08 4113.01
Description: EFCO 433 FRONTSET Paragraph: 2.02
STORE FRONT SYSTEM Page No.: 5

Proposed Substitution: SERIES 3000 THERMAL MULTIPLANE
Trade Name: _____ Model No.: S-3000 FRONT SET
Manufacturer: OLDCASTLE
Address: 4200 INDUSTRY DR E, FIFE, WA Phone No.: 253-922-5258

Attached data includes product description, specifications, drawings, photographs, and performance and test data adequate for evaluation of the request; applicable portions of the data are clearly identified.

Attached data also includes a description of changes to the Contract Documents that the proposed substitution will require for its proper installation.

The Undersigned certifies:

- Proposed substitution has been fully investigated and determined to be equal or superior in all respects to specified product.
- Same warranty will be furnished for proposed substitution as for specified product.
- Same maintenance service and source of replacement parts, as applicable, is available.
- Proposed substitution will have no adverse effect on other trades and will not affect or delay progress schedule.
- Proposed substitution does not affect dimensions and functional clearances.
- Payment will be made for changes to building design, including A/E design, detailing, and construction costs caused by the substitution.

Submitted By: CHRIS MUIR
Signed By: [Signature] Firm: REGIONAL GLASS
Address: 6 - 37th STREET NW
AUBURN, WA. 98001
Telephone: 253-737-4730 Email: CHRIS@REGIONALGLASSNW.COM

Supporting Data Attached:

- Drawings Product Data Samples Tests Reports Other _____

ENGINEER'S REVIEW AND ACTION

- Substitution approved
 Substitution approved as noted
 Substitution rejected - Use specified materials.
 Substitution Request received too late - Use specified materials.

Signed by: [Signature] Date: 5/9/16

Series 3000 Thermal MultiPlane— the versatility of standard storefront systems with improved thermal performance

The Series 3000 Thermal MultiPlane extends the versatility of standard storefront systems by offering **improved thermal performance** and multiple glass plane options. The Series 3000 provides more options for head and sill anchorage, **structural silicone glazing** and a front set installation option utilizing continuous head and sill members. Designed for 1" infill, Series 3000 Thermal MultiPlane has available glazing adapters and gasket options for infills ranging from 1/4" to 1-1/8".

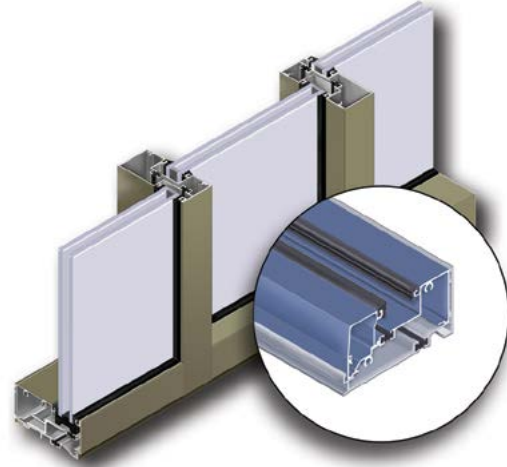

First Community Credit Union, St. Louis, MO
Architect: TR,i Architects

Features

- Overall system dimensions: 2" x 4-1/2"
- Front Set, Center Set, Back Set or Multi-set glazing configurations
- Optional sill receptor requires no additional anchoring of sill member
- Optional thermally broken head anchor clip
- SSG glazing with patented funnel bridge
- Continuous head and sill assembly option for front set
- Screw spline and shear block assembly
- Outside and inside glazing options
- Complete 90° and 135° corners
- High sidelite base
- Thermally broken members with polyurethane thermal breaks
- Accommodates ZS-2750 vents
- Factory painted Kynar 500®/Hylar 5000® finishes, meeting all provisions of AAMA 2605
- Factory anodized finishing



Product Details

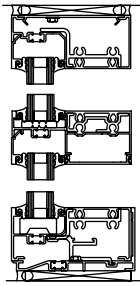

Front Set

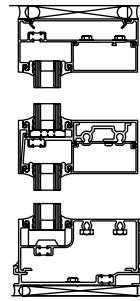
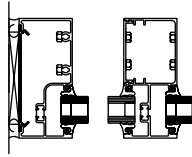

Front Set SSG

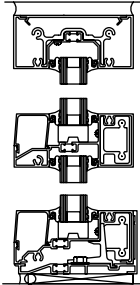
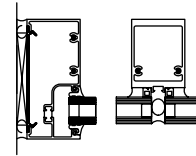

Center Set

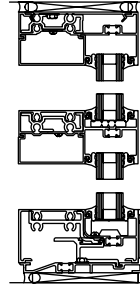
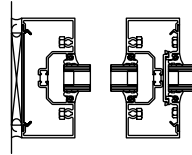

Back Set

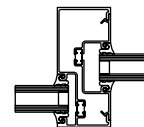
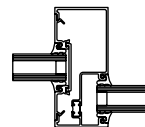
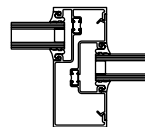
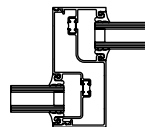
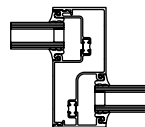
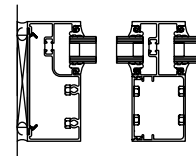

Multi-Set

Performance

Air Infiltration	<.06 CFM/SQ FT (6.24 PSF) per ASTM E283
Static Water	10 PSF per ATSM E331
Deflection Load	40 PSF per ASTM E330
Structural Load	60 PSF per ASTM E330
STC	
32 (1/4" - 1/2" - 1/4" glazing) -	Center and Front Set
37 (1/4" laminated - 1/2" - 1/4" laminated glazing) -	Center Set
38 (1/4" laminated - 1/2" - 1/4" laminated glazing) -	Front Set
High-performance per AAMA 1503 for Clear 1" Insulating Glass:	
U-Factor = 0.54, CRF frame = 69	Front Set
U-Factor = 0.56, CRF frame = 58	Center Set
U-Factor = 0.51, CRF frame = 57	Back Set
NFRC Tested and Certified	

Kynar 500® is a registered trademark of Atofina
 Hylar 5000® is a registered trademark of Ausimont USA, Inc.



Series 433

2" x 4 1/2" Thermal Triple Set® Storefront Framing



CONFIGURATIONS

Screw Spline • Shear Block

System 433 is a thermally broken storefront framing system. Glass planes can be placed in an outside set, center set or inside set configuration, which gives you design flexibility to meet any multi-plane glazing specification. Series 433 is compatible with all EFCO entrances.

Features

Benefits

Thermally broken frames	Enhanced thermal performance
Three glass planes	Create shadow box effect, match vision of architect
All joints and horizontal mullions are square cut	Facilitates shop fabrication of "ladders" that can be transported as a unit to job sites for quick installation
Door frames will accommodate glass in three planes	Allows quick fabrication in the field
90° and 135° inside and outside corner mullions	Glass plane effect can continue at door frames
All joint fasteners are #12 screws	Accommodates multifaceted elevations
Steel is available for mullions as stock steel bars or custom fabricated steel shapes	Utilizes a common mullion with standard verticals attached to reduce number of dies
Accommodates up to 1 1/16" glazing	Strengthens system to allow transportation of ladders without damage to joinery system
Inside or outside glazing in all glass planes	Simplifies fabrication
Uniform glazing gasket is used for exterior and interior	Eliminates the cost of customer steel fabrication
Stock length or fabricated	Allows system performance enhancements
Anodized or painted finishes available	Energy savings options
	Allows flexibility of construction methods
	Allows optimized use of gasket
	Simplifies ordering and installation
	Provides customers with an option
	Multiple options to answer economic and aesthetic concerns

Series 433

2" x 4 1/2" Thermal Triple Set® Storefront Framing

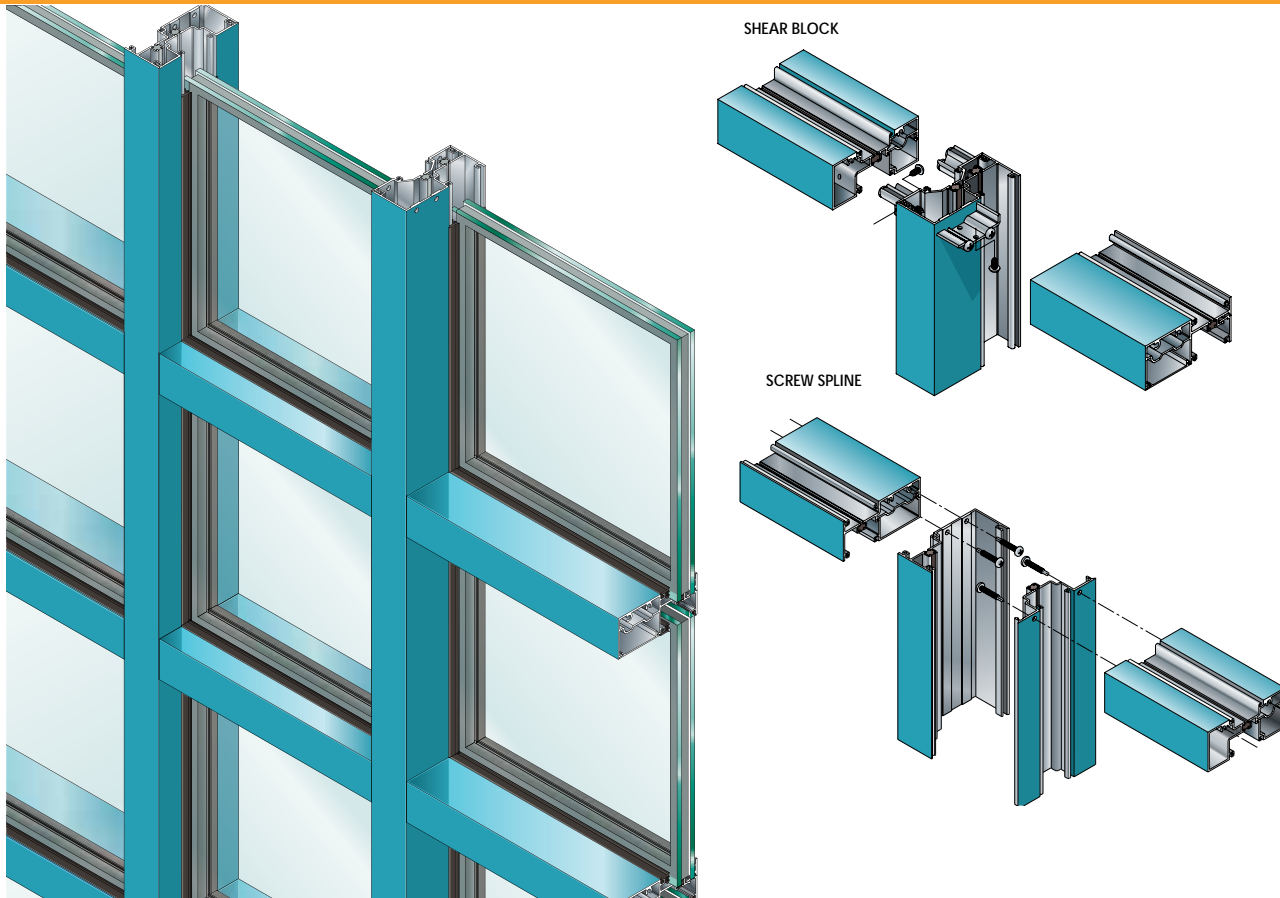

PERFORMANCE DATA

SYSTEM 433 STOREFRONT FRAMING

AIR INFILTRATION	<.06 CFM/SF @ 6.24 PSF
WATER	NO LEAKAGE @ 10.0 PSF
STRUCTURAL	visit MyEFCO at www.efccorp.com
CRF-FRAME	67
CRF-GLASS	66

Note: All performance value data is based on laboratory testing per AAMA 101/1.S.2/A440 for Air/Water/Structural, ASTM E90 and or E413 for Acoustical, AAMA 507 and or NFRC 100/200/500 for UFactors and AAMA 1503 for Condensation Resistance Factor (CRF). Printed values are subject to change pending the frequency of recertification testing. Field results will vary depending on size, the field test method, the addition of sub-frames, panning, mullions, accessories and installation into the surrounding condition.

GLAZING

SYSTEM 433 CAN BE INSIDE OR OUTSIDE GLAZED WITH EXTRUDED ALUMINUM, SNAP-IN GLAZING BEAD. GLASS IS "DRY GLAZED" WITH TOP LOAD GASKET. GLAZING OF 3/16" TO 1-1/16" INFILL PANELS ARE ACCOMMODATED. SEE GLAZING CHART BELOW FOR EXACT SIZE.

433 THERMAL U-FACTORS*		
CENTER OF GLASS U-FACTOR	CONFIGURATION AND SIZE	
	FX/FX** 78 3/4" X 78 3/4"	FX/FX 120" X 120"
0.46	0.56	0.51
0.34	0.46	0.41
0.30	0.43	0.37
0.24	0.39	0.32
0.20	0.35	0.28

* Based on NFRC 100
**NFRC Gateway size

SYSTEM 433 GLAZING CHART	POLYCARBONATE			GLASS OR PANEL												
	3/16"	1/4"	5/16"	3/16"	1/4"	1/4**	5/16"	7/16"	1/2"	9/16"	5/8"	3/4"	7/8"	15/16"	1"	1-1/16"
MONOLITHIC GLASS	C	C	C	C	C	C	C	C	C	C	C					
INSULATED GLASS												C		C	A	C

*-Obscure glass thickness
**-Laminated glass thickness

A - Available glazing option
C - Adaptor and/or gasket required
Blank - N/A



Series 433

2" x 4 1/2" Thermal Triple Set® Storefront Framing

Frame Construction

Members are extruded 6063-T6 aluminum alloy with a nominal wall thickness of .080". Corner construction employs a screw spline or shear block method and utilize #12 fasteners. Frame members have a face sight line of 2" and frame depth of 4 1/2". See Illustration 1 & 2 for system joinery.

Glass planes can be placed in an outside set, center set, or inside set configuration. Both inside and outside glazing is available. 90° and 135° inside and outside corners are available.

Door Frames

Series 433 offers integral entrance frames in shear block construction. Members are nominally .080" in thickness. A standard entrance header is available as well as an entrance header that is designed for use with concealed overhead closers. Transom lite glazing is accommodated through either applied glass stops and glazing beads or extruded in place glazing pockets. Door stops are available as extruded in place or screw applied configurations.

Weather Stripping

All entrance frames are weather-stripped with bulb gasket.

Thermal Barrier

All frames and vents are thermally broken using the latest technology in two part, high density polyurethane.

Glazing

Series 433 can be inside or outside glazed with extruded aluminum, snap-in glazing bead. Glass is "dry glazed" with top load gasket. Glazing of 3/16" to 1 1/16" infill panels are accommodated. See Glazing Chart for exact size.

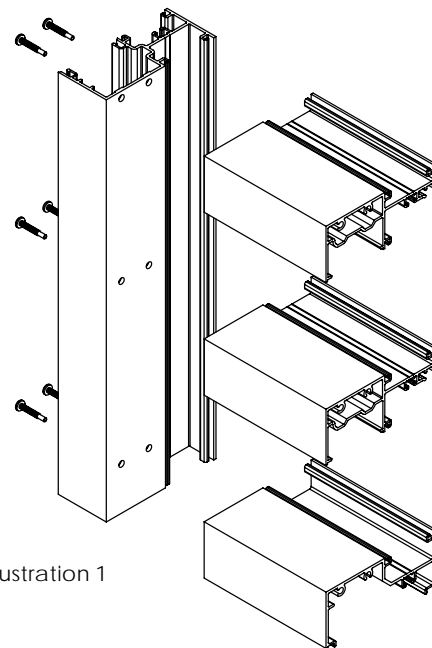

Illustration 1

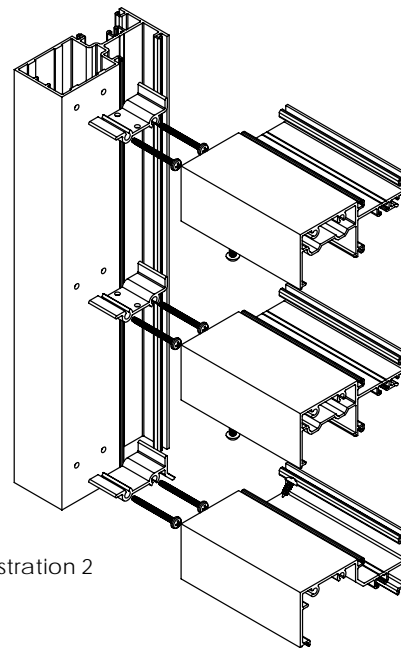

Illustration 2